



THREAD

LINE

THREAD LINE

THREAD LINE

THREAD LINE

● First choice ○ Suitable

Reference	Picture	Thread style	Page	Description	Coating	Ø Range (mm)	Tolerance	Thread Form	
								Trough h.	Blind h.
4990		M	138	Threading mill - Solid Carbide	TiAlN	M2 - M12		●	●
4991		M-MF	140	Threading mill - Solid Carbide	TiAlN	M4 - M16		●	●
48.7010		M	142	Forming tap HSSE	TiN Up	M3 - M10	6HX	●	●
48.7016		M	143	Forming tap HSSE	TiN Up	M12 - M20	6HX	●	●
40.1040		M	144	Universal tap HSSE	Black HVA	M3 - M10	6H	●	
40.1046		M	145	Universal tap HSSE	Black HVA	M12 - M20	6H	●	
40.1640		M	146	Universal tap HSSE 6G tolerance	Black HVA	M3 - M10	6G	●	
40.1140		MF	148	Universal tap HSSE	Black HVA	MF4 - MF20	6H	●	
40.1240		GAS (BSP)	149	Universal tap HSSE	Black HVA	G 1/8 - G 1"	6H	●	
40.1340		UNF (SAE)	150	Universal tap HSSE	Black HVA	UNF4 - UNF 5/8	2B	●	
40.1440 40.1446		UNC	151	Universal tap HSSE	Black HVA	UNC 4 - UNC 3/4 UNC 7/8 - UNC 3/4	2B	●	
41.6040		M	152	Universal tap HSSE PM	TiN Up	M2 - M10	6H	●	
41.6046		M	153	Universal tap HSSE PM	TiN Up	M12 - M20	6H	●	
45.5040		M	154	High performance tap HSSE	DSC	M2 - M10	6HX	●	
45.5046		M	155	High performance tap HSSE	DSC	M12 - M30	6HX	●	
45.5144		MF	156	High performance tap HSSE	DSC	MF6 - MF24	6HX	●	
45.5245		GAS (BSP)	157	High performance tap HSSE	DSC	G 1/16 - G 1"	-	●	
44.0040		M	158	Tap for Aluminium HSSE	Bright	M3 - M10	6H	●	
44.0046		M	159	Tap for Aluminium HSSE	Bright	M12 - M20	6H	●	
43.2810		M	160	Tap HSSE-PM for Cast Iron and Steel. Internal Coolant	TiCN	M5 - M10	6HX	●	●
43.2816		M	161	Tap HSSE-PM for Cast Iron and Steel. Internal Coolant	TiCN	M10 - M14	6HX	●	●
43.2117		MF	163	Tap HSSE-PM for Cast Iron and Steel. Internal Coolant	TiCN	MF5 - MF16	6HX	●	●
46.4040		M	164	Inconel, Nickel alloys	TiCN	M3 - M10	6HX	●	
46.4046		M	165	Inconel, Nickel alloys	TiCN	M12 - M16	6HX	●	























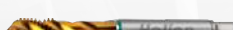

THREAD LINE

NORM	UNI					INOX	GG/G	TITAN	Non Ferrous		HSC	HHC	HPC
		500N/mm ² <1200N/mm ²	800N/mm ² <1400N/mm ²	42-54 HRC	48-63 HRC	Stainless Steel	Cast Iron	Inconel/ Hastelloy	ALU NE	PLAS- TIC	High Speed Cutting	High Hard Cutting	High Performance Cutting
Helion	●	●	●	●	●	●	●	●	○	○	●	●	●
Helion	●	●	●	●	●	●	●	●	○	○	●	●	●
2174	●	●	○		●	●			○	○			
2174	●	●	○		●	●			○	○			
371	●	●	○		●	●			○	○			
376	●	●	○		●	●			○	○			
371	●	●	○		●	●			○	○			
376	●	●	○		●	●			○	○			
5156	●	●	○		●	●			○	○			
371/376	●	●	○		●	●			○	○			
371/376	●	●	○		●	●			○	○			
371	●	●	●		●	○			○	○	●		●
376	●	●	●		●	○			○	○	●		●
371		●	●		●	○	○		○	○	●		●
371		●	●		●	○	○		○	○	●		●
376		●	●	●	●	○	○		○	○	●		●
5156		●	●		●	○	○		○	○	●		●
371									●	●	●		●
376									●	●	●		●
371			● > 1000 N/mm ²			●			○				●
376			● > 1000 N/mm ²			●			○				●
376			● > 1000 N/mm ²			●			○				●
371					○		●						●
376					○		●						●

THREAD LINE

THREAD LINE

● First choice ○ Suitable

Reference	Picture	Thread style	Page	Description	Coating	Ø Range (mm)	Tolerance	 Trough h.	 Blind h.
43.2010		M	166	Tap for hardened steel HSSE- PM	TiCN		6HX	●	●
47.9010		M	167	Tap for hardened steel Solid Carbide	TiCN		6H	●	●
40.1060		M	168	Universal tap HSSE	Black HVA		6H	○	●
40.1066		M	169	Universal tap HSSE	Black HVA		6H	○	●
40.1050		M	170	Universal tap HSSE Form E	Black HVA		6H	○	●
40.1660		M	171	Universal tap HSSE 6G tolerance	Black HVA		6G	○	●
40.1160		MF	172	Universal tap HSSE	Black HVA	MF4 - MF20	6H	○	●
40.1260		GAS (BSP)	173	Universal tap HSSE	Black HVA	G 1/8 - G 1"	-	○	●
40.1360		UNF (SAE)	174	Universal tap HSSE	Black HVA	UNF4 - UNF 5/8	2B	○	●
40.1460 40.1466		UNC	175	Universal tap HSSE	Black HVA	UNC 4 - UNC 3/4 UNC 7/16 - UNC 3/4	2B	○	●
40.7068		M	176	Universal tap HSSE long	TiN Up		6HX	○	●
40.7060		M	178	Universal tap HSSE	TiN Up		6H	○	●
40.7066		M	179	Universal tap HSSE	TiN Up		6HX	○	●
41.6050		M	180	Universal tap HSSE PM	TiN Up		6H	○	●
41.6056		M	181	Universal tap HSSE PM	TiN Up		6H	○	●
45.4060		M	182	High performance tap HSSE	TiAlN		6HX	○	●
45.4066		M	183	High performance tap HSSE	TiAlN		6HX	○	●
45.4164		MF	184	High performance tap HSSE	TiAlN	MF6 - MF24	6HX	○	●
45.3265		GAS (BSP)	185	High performance tap HSSE	TiAlN	G1/16 - G 1"	-	○	●
44.0060		M	186	Tap for Aluminium HSSE	Bright		6H	○	●
44.0066		M	187	Tap for Aluminium HSSE	Bright		6H	○	●
46.4070		M	188	Inconel, Nickel alloys	TiAlN		6HX	○	●
46.4076		M	189	Inconel, Nickel alloys	TiAlN		6HX	○	●

THREAD LINE





NORM	UNI					INOX	GG/G	TITAN	Non Ferrous		HSC	HHC	HPC
		500N/mm ² <1200N/mm ²	800N/mm ² <1400N/mm ²	42-54 HRC	48-63 HRC	Stainless Steel	Cast Iron	Inconel/ Hastelloy	ALU NE	PLAS- TIC	High Speed Cutting	High Hard Cutting	High Performance Cutting
Helion			○	●								●	●
Helion				○	●							●	●
371	●	●	○		●	●			○	○			
376	●	●	○		●	●			○	○			
371-E	●	●	○		●	●			○	○			
371	●	●	○		●	●			○	○			
376	●	●	○		●	●			○	○			
5156	●	●	○		●	●			○	○			
374C	●	●	○		●	●			○	○			
374C	●	●	○		●	●			○	○			
Helion	●	●	○		●	●			○	○			
371	●	●	○		●	●			○	○			
376	●	●	○		●	●			○	○			
371	●	●	●		●	○			○	○	●		●
376	●	●	●		●	○			○	○	●		●
371	●	○			●	○	○		○		●		●
376	●	○			●	○	○		○		●		●
376	●	○			●	○	○		○		●		●
5156	●	○			●	○	○		○		●		●
371													
376													
371					○		●						●
376					○		●						●

THREAD LINE

4990

SOLID CARBIDE THREAD MILL 2xD



-  Fresa de roscar MD 2xD
-  Fraise à fileter en carbure 2xD
-  Fresa a filettare in metallo duro 2xD
-  Твердосплавные резьбофрезы 2xD

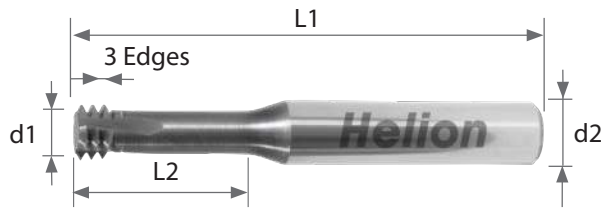



600
1400
N/mm²

45
HRC

55
HRC



TiAlN

UNI

HA

HPC

NEW

HELION
NORM

p-190

M

Cod.	M	d1	P	d2	L1	L2	Z	Previous Hole Ø	Price €
4990M20040	M 2,0	1,55	0,40	3,00	39	4,50	3	1,60	
4990M22045	M 2,2	1,65	0,45	6,00	54	5,00	3	1,75	
4990M25045	M 2,5	1,95	0,45	6,00	54	5,50	3	2,05	
4990M30050	M 3,0	2,35	0,50	6,00	54	6,50	3	2,50	
4990M35060	M 3,5	2,75	0,60	6,00	54	7,50	3	2,90	
4990M40070	M 4,0	3,10	0,70	6,00	54	9,00	3	3,30	
4990M45075	M 4,5	3,40	0,75	6,00	54	10,50	3	3,75	
4990M50080	M 5,0	3,80	0,80	6,00	54	12,50	3	4,20	
4990M60100	M 6,0	4,65	1,00	6,00	54	14,00	3	5,00	
4990M80125	M 8,0	5,95	1,25	6,00	54	18,00	3	6,75	
4990M10150	M 10,0	7,80	1,50	8,00	64	23,00	3	8,50	
4990M12175	M 12,0	9,00	1,75	10,00	73	26,00	3	10,25	

THREAD MILLING PROCESS

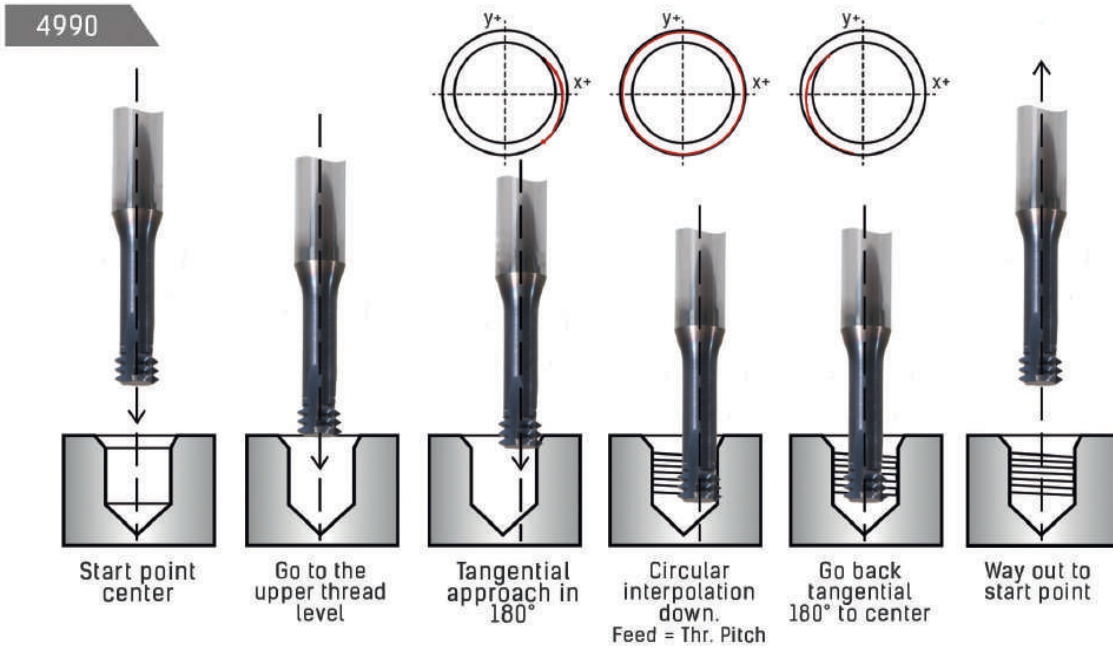
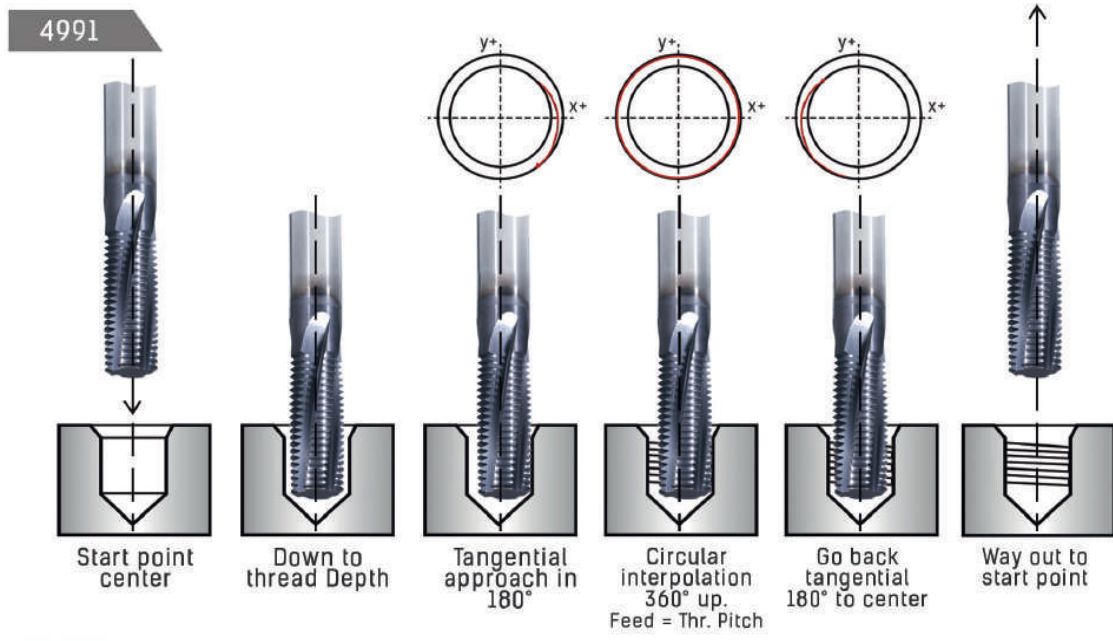

MILL THREADING ADVANTAGES

one tool can...

1.2311 316-L
1.2379 St 52
G-AISI 12 GG-25
HARDOX-400

Thread a wide range of materials

M-16x1,50 M-20x1,50

Thread different diameters to the same thread pitch





Optimal in fine pitch

Thread right or left hand. Several ways of tapping

4991



SOLID CARBIDE THREAD MILL 2xD

-  Fresa de roscar MD HeliNorm 2xD
-  Fraise à fileter en carbure 2xD
-  Fresa a filettare in metallo duro 2xD
-  Твердосплавные резьбофрезы 2xD

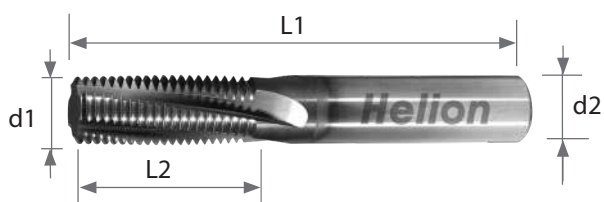





				p-191

M
MF

Cod.	M	d1	P	d2	L1	L2	Z	Previous Hole Ø	Price €
4991M40070	M 4	3,10	0,70	6	55	8	3	3,30	
4991M50080	M 5	4,00	0,80	6	55	12	3	4,20	
4991M60100	M 6	4,50	1,00	6	55	12	3	5,00	
4991M60100	M 7	4,50	1,00	6	55	12	3	6,00	
4991MF80100	MF 8	6,00	1,00	6	55	15	3	7,00	
4991M80125	M 8	6,00	1,25	6	55	15	3	6,80	
4991MF10100	MF 10	8,00	1,00	8	66	20	3	9,00	
	MF 12	8,00	1,00	8	66	20	3	11,00	
4991MF12125	MF 10	8,00	1,25	8	66	20	3	8,80	
	MF 12	8,00	1,25	8	66	20	3	10,80	
4991M10150	M 10	8,00	1,50	8	66	20	3	8,50	
	MF 12	8,00	1,50	8	66	20	3	10,50	
4991M12175	M 12	8,00	1,75	8	66	20	3	10,20	
4991MF14150	MF 14	10,00	1,50	10	80	25	4	13,50	
4991M14200	M 14	10,00	2,00	10	80	25	4	12,00	
4991MF16150	MF 16	12,00	1,50	12	82	30	4	14,50	
4991M16200	M 16	12,00	2,00	12	82	30	4	14,00	

48.7010

FORMING TAP HSS-E TIN D2174C

-  Macho roscar laminación HSS-E TiN D2174C
-  Taraud machine a refouler HSS-E TiN D2174C
-  Maschio a rullare HSS-E TiN DIN 2174C
-  Бесстружечные метчики (раскатники) HSS-E TiN D2174C

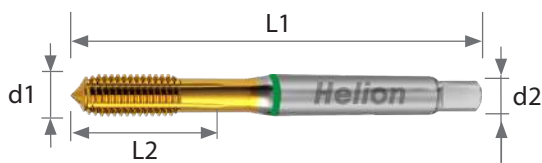

6HX
tolerance

TiN
Up

UNI

INOX





DIN
2174



 HA

HPC







 p-192

M

Cod.	M	d1	P	d2	L1	L2	Prev. Hole Ø	Price €
487010M03	M3	3,00	0,50	3,50	56	10	2,80	
487010M04	M4	4,00	0,70	4,50	63	12	3,70	
487010M05	M5	5,00	0,80	6,00	70	14	4,65	
487010M06	M6	6,00	1,00	6,00	80	16	5,55	
487010M08	M8	8,00	1,25	8,00	90	17	7,40	
487010M10	M10	10,00	1,50	10,00	100	20	9,30	

FORMING TAP HSS-E TIN D2174C

48.7016

-  Macho roscar laminación HSS-E TiN D2174C
-  Taraud machine a refouler HSS-E TiN D2174C
-  Maschio a rullare HSS-E TiN DIN 2174C
-  Бесстружечные метчики (раскатники) HSS-E TiN D2174C

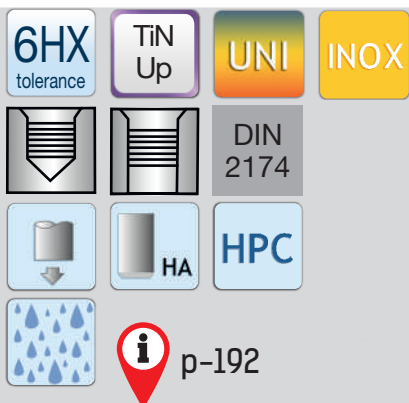
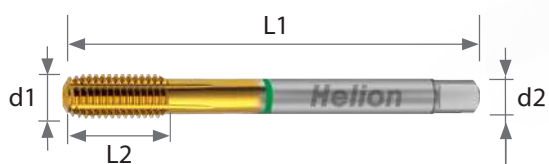





M

Cod.	M	d1	P	d2	L1	L2	Prev. Hole Ø	Price €
487016M12	M12	12,00	1,75	9,00	110	24	11,20	
487016M16	M16	16,00	2,00	12,00	110	26	15,10	
487016M20	M20	20,00	2,50	16,00	140	32	18,90	

40.1040

UNIVERSAL MACHINE TAP FIRST CHOICE HSS-E



-  Macho de máquina multiuso HSS-E
-  Taraud machine universel HSS-E
-  Maschio a macchina universale HSS-E
-  Машинные метчики общего применения HSS-E

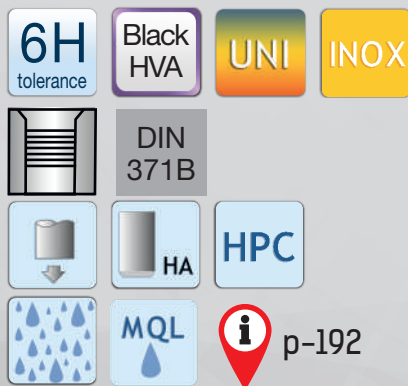





M

Cod.	M	d1	P	d2	L1	L2	Prev. Hole Ø	Price €
401040M03	M3	3,00	0,50	3,50	56	10	2,50	
401040M04	M4	4,00	0,70	4,50	63	12	3,20	
401040M05	M5	5,00	0,80	6,00	70	14	4,20	
401040M06	M6	6,00	1,00	6,00	80	16	5,00	
401040M08	M8	8,00	1,25	8,00	90	17	6,80	
401040M10	M10	10,00	1,50	10,00	100	20	8,50	









UNIVERSAL MACHINE TAP FIRST CHOICE HSS-E

40.1046

-  Macho de máquina multiuso HSS-E
-  Taraud machine universel HSS-E
-  Maschio a macchina universale HSS-E
-  Машинные метчики общего применения HSS-E



THREAD LINE





M

Cod.	M	d1	P	d2	L1	L2	Prev. Hole Ø	Price €
401046M12	M12	12,00	1,75	9,00	110	24	10,20	
401046M14	M14	14,00	2,00	11,00	110	26	12,00	
401046M16	M16	16,00	2,00	12,00	110	26	14,00	
401046M20	M20	20,00	2,50	16,00	140	32	17,50	

40.1640

UNIVERSAL MACHINE TAP 6G TOLERANCE HSS-E



-  Macho de máquina multiuso Tol. 6G HSS-E
-  Taraud machine universel Tol. 6G HSS-E
-  Maschio a macchina universale tolleranza 6G HSS-E
-  Машинные метчики общего применения "6G" HSS-E





6G
tolerance

Black
HVA

UNI

INOX

 DIN
371B

 HA

 MQL

 p-192

M

Cod.	M	d1	P	d2	L1	L2	Prev. Hole Ø	Price €
401640M03	M3	3,00	0,50	3,50	56	10	2,50	
401640M04	M4	4,00	0,70	4,50	63	12	3,20	
401640M05	M5	5,00	0,80	6,00	70	14	4,20	
401640M06	M6	6,00	1,00	6,00	80	16	5,00	
401640M08	M8	8,00	1,25	8,00	90	17	6,80	
401640M10	M10	10,00	1,50	10,00	100	20	8,50	

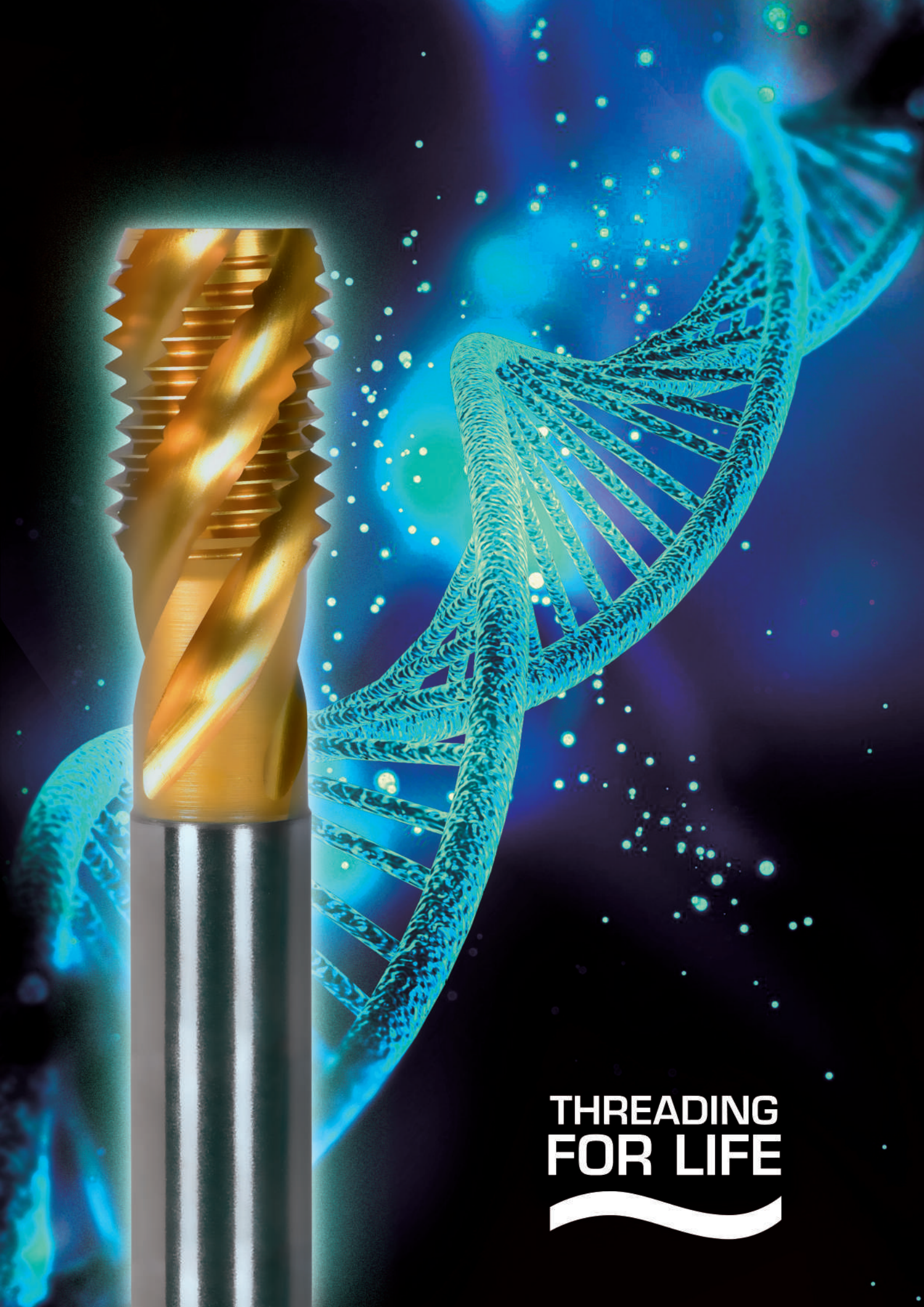





**THREADING
FOR LIFE**



40.1140

UNIVERSAL MACHINE TAP FIRST CHOICE HSS-E



-  Macho de máquina multiuso HSS-E
-  Taraud machine universel HSS-E
-  Maschio a macchina universale HSS-E
-  Машинные метчики общего применения HSS-E





6H
tolerance

Black
HVA

UNI

INOX

 DIN
376B

 HA

 MQL





 p-192

MF

Cod.	M	d1	P	d2	L1	L2	Prev. Hole Ø	Price €
401140MF405	MF4	4,00	0,50	2,80	63	8	3,50	
401140MF505	MF5	5,00	0,50	3,50	70	10	4,50	
401140MF6075	MF6	6,00	0,75	4,50	80	13	5,20	
401140MF81	MF8	8,00	1,00	6,00	90	16	7,00	
401140MF101	MF10	10,00	1,00	7,00	90	16	9,00	
401140MF121	MF12	12,00	1,00	9,00	100	20	11,00	
401140MF1215	MF12	12,00	1,50	9,00	100	20	10,50	
401140MF1415	MF14	14,00	1,50	11,00	100	20	12,50	
401140MF1615	MF16	16,00	1,50	12,00	100	22	14,50	
401140MF2015	MF20	20,00	1,50	16,00	125	25	18,50	

UNIVERSAL MACHINE TAP FIRST CHOICE HSS-E

40.1240

-  Macho de máquina multiuso HSS-E
-  Taraud machine universel HSS-E
-  Maschio a macchina universale HSS-E
-  Машинные метчики общего применения HSS-E



THREAD LINE

6H
tolerance

Black
HVA

UNI

INOX

 DIN
5156

 HA

 MQL

 p-192





**GAS
BSP**

Cod.	Size	d1	P	d2	L1	L2	Prev. Hole Ø	Price €
401240G1/8	G1/8	9,73	28	7,00	90	18	8,80	
401240G1/4	G1/4	13,16	19	11,00	100	20	11,80	
401240G3/8	G3/8	16,66	19	12,00	100	22	15,25	
401240G1/2	G1/2	20,96	14	16,00	125	25	19,00	
401240G3/4	G3/4	26,44	14	20,00	140	28	24,50	
401240G1	G1"	33,25	11	25,00	160	30	30,75	

40.1340

UNIVERSAL MACHINE TAP FIRST CHOICE HSS-E



-  Macho de máquina multiuso HSS-E
-  Taraud machine universel HSS-E
-  Maschio a macchina universale HSS-E
-  Машинные метчики общего применения HSS-E





2B
tolerance

Black
HVA

UNI

INOX

 DIN
371

 DIN
376

 HA

 MQL





 p-192

**UNF
SAE**

Cod.	Size	d1	P	d2	L1	L2	Prev. Hole Ø	Price €
401340NF448	UNF 4	2,85	48	2,20	56	10	2,40	
401340NF640	UNF 6	3,51	40	2,50	56	11	2,95	
401340NF1032	UNF 10	4,83	32	3,50	70	14	4,10	
401340NF1428	UNF 1/4	6,35	28	4,50	80	16	5,50	
401340NF3824	UNF 3/8	9,53	24	7,00	90	18	8,50	
401340NF5818	UNF 5/8	15,88	18	12,00	100	22	14,50	

40.1440
40.1446

UNIVERSAL MACHINE TAP FIRST CHOICE HSS-E

-  Macho de máquina multiuso HSS-E
-  Taraud machine universel HSS-E
-  Maschio a macchina universale HSS-E
-  Машинные метчики общего применения HSS-E



THREAD LINE

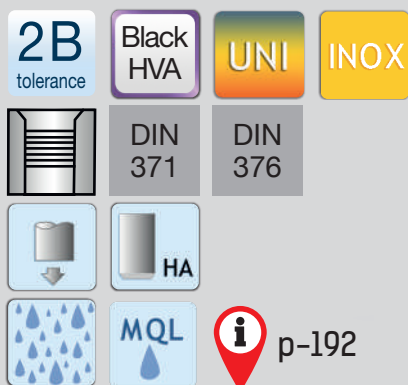





UNC

Cod.	Size	d1	P	d2	L1	L2	Prev. Hole Ø	Price €
401440NC440	UNC 4	2,85	40	3,50	56	11	2,35	
401440NC632	UNC 6	3,51	32	4,00	56	12	2,85	
401440NC832	UNC 8	4,17	32	4,50	63	12	3,50	
401440NC1024	UNC 10	4,83	24	6,00	70	14	3,90	
401440NC1420	UNC 1/4	6,35	20	7,00	80	16	5,10	
401440NC51618	UNC 5/16	7,94	18	8,00	90	18	6,60	
401440NC3816	UNC 3/8	9,53	16	10,00	100	20	8,00	
401446NC71614	UNC 7/16	11,11	14	8,00	100	22	9,40	
401446NC1213	UNC 1/2	12,70	13	9,00	110	25	10,80	
401446NC5811	UNC 5/8	15,88	11	12,00	110	30	13,50	
401446NC3410	UNC 3/4	19,05	10	14,00	125	33	16,50	





41.6040

UNIVERSAL MACHINE TAP PERFORMANCE HSS-E-PM



-  Macho de máquina multiuso producción HSS-E-PM
-  Taraud machine universel performance HSS-E-PM
-  Maschio a macchina universale ad alta prestazione HSS-E-PM
-  Машинные метчики общего применения HSS-E-PM







6H tolerance	600 1400 N/mm ²	INOX	TiN Up	UNI
	DIN 371B	HSS-E PM		
	HA	HPC		
	MQL	NEW	 p-192	

M













Cod.	M	d1	P	d2	L1	L2	Prev. Hole Ø	Price €
416040M02	M2	2,00	0,40	2,80	45	8	1,60	
416040M03	M3	3,00	0,50	3,50	56	10	2,50	
416040M04	M4	4,00	0,70	4,50	63	12	3,20	
416040M05	M5	5,00	0,80	6,00	70	14	4,20	
416040M06	M6	6,00	1,00	6,00	80	16	5,00	
416040M08	M8	8,00	1,25	8,00	90	17	6,80	
416040M10	M10	10,00	1,50	10,00	100	20	8,50	

UNIVERSAL MACHINE TAP PERFORMANCE HSS-E-PM

41.6046

-  Macho de máquina multiuso producción HSS-E-PM
-  Taraud machine universel performance HSS-E-PM
-  Maschio a macchina universale ad alta prestazione HSS-E-PM
-  Машинные метчики общего применения HSS-E-PM







M

Cod.	M	d1	P	d2	L1	L2	Prev. Hole Ø	Price €
416046M12	M12	12,00	1,75	9,00	110	24	10,20	
416046M14	M14	14,00	2,00	11,00	110	26	12,00	
416046M16	M16	16,00	2,50	12,00	110	26	14,00	
416046M18	M18	18,00	2,00	14,00	125	30	15,50	
416046M20	M20	20,00	2,50	16,00	140	32	17,50	

45.5040

HIGH PERFORMANCE MACHINE TAP HSS-E



-  Macho de máquina alto rendimiento HSS-E
-  Taraud machine haute performance HSS-E
-  Maschio a macchina ad alta prestazione HSS-E
-  Машинные метчики высокопроизводительные HSS-E





6HX
tolerance

**600
1400**
N/mm²

INOX

DSC

 **DIN
371B**

 **HA**

HPC

HSC

 **NEW**





 **p-192**

M

Cod.	M	d1	P	d2	L1	L2	Prev. Hole Ø	Price €
455040M02	M2	2,00	0,40	2,80	45	8	1,60	
455040M025	M2,5	2,50	0,45	2,80	50	9	2,05	
455040M03	M3	3,00	0,50	3,50	56	10	2,50	
455040M04	M4	4,00	0,70	4,50	63	12	3,30	
455040M05	M5	5,00	0,80	6,00	70	14	4,20	
455040M06	M6	6,00	1,00	6,00	80	16	5,00	
455040M08	M8	8,00	1,25	8,00	90	17	6,80	
455040M10	M10	10,00	1,50	10,00	100	20	8,50	











HIGH PERFORMANCE MACHINE TAP HSS-E

45.5046

-  Macho de máquina alto rendimiento HSS-E
-  Taraud machine haute performance HSS-E
-  Maschio a macchina ad alta prestazione HSS-E
-  Машинные метчики высокопроизводительные HSS-E



THREAD LINE

			
			
			
	 p-192		





M

Cod.	M	d1	P	d2	L1	L2	Prev. Hole Ø	Price €
455046M12	M12	12,00	1,75	9,00	110	24	10,20	
455046M14	M14	14,00	2,00	11,00	110	26	12,00	
455046M16	M16	16,00	2,00	12,00	110	26	14,00	
455046M18	M18	18,00	2,50	14,00	125	30	15,50	
455046M20	M20	20,00	2,50	16,00	140	32	17,50	
455046M24	M24	24,00	3,00	18,00	160	36	21,00	
455046M30	M30	30,00	3,50	22,00	180	40	26,50	

45.5144

HIGH PERFORMANCE MACHINE TAP HSS-E



-  Macho de máquina alto rendimiento HSS-E
-  Taraud machine haute performance HSS-E
-  Maschio a macchina ad alta prestazione HSS-E
-  Машинные метчики высокопроизводительные HSS-E



6HX
tolerance

600
1400
N/mm²

INOX

DSC

DIN
376B

HA

HPC

HSC

MQL

NEW





p-192

MF

Cod.	M	d1	P	d2	L1	L2	Prev. Hole Ø	Price €
455144MF6075	MF6	6,00	0,75	4,50	80	13	5,20	
455144MF8075	MF8	8,00	0,75	6,00	80	14	7,20	
455144MF81	MF8	8,00	1,00	6,00	90	16	7,00	
455144MF101	MF10	10,00	1,00	7,00	90	16	9,00	
455144MF10125	MF10	10,00	1,25	7,00	100	20	8,80	
455144MF121	MF12	12,00	1,00	9,00	100	20	11,00	
455144MF12125	MF12	12,00	1,25	9,00	100	20	10,80	
455144MF1215	MF12	12,00	1,50	9,00	100	20	10,50	
455144MF1415	MF14	14,00	1,50	11,00	100	20	12,50	
455144MF1615	MF16	16,00	1,50	12,00	100	22	14,50	
455144MF1815	MF18	18,00	1,50	14,00	110	25	16,50	
455144MF2015	MF20	20,00	1,50	16,00	125	25	18,50	
455144MF2415	MF24	24,00	1,50	18,00	140	28	22,50	

HIGH PERFORMANCE MACHINE TAP HSS-E

45.5245

-  Macho de máquina alto rendimiento HSS-E
-  Taraud machine haute performance HSS-E
-  Maschio a macchina ad alta prestazione HSS-E
-  Машинные метчики высокопроизводительные HSS-E



THREAD LINE

600
1400
N/mm²

INOX

DSC

DIN
5156

HPC

HSC

MQL

NEW

p-192





**GAS
BSP**

Cod.	Size	d1	P	d2	L1	L2	Prev. Hole Ø	Price €
455245G116	GAS1/16	7,72	28	6,00	90	18	6,80	
455245G18	GAS1/8	9,73	28	7,00	90	18	8,80	
455245G14	GAS1/4	13,16	19	11,00	100	20	11,80	
455245G38	GAS3/8	16,66	19	12,00	100	22	15,25	
455245G12	GAS1/2	20,96	14	16,00	125	25	19,00	
455245G58	GAS5/8	22,91	14	18,00	125	25	21,00	
455245G34	GAS3/4	26,44	14	20,00	140	28	24,50	
455245G78	GAS7/8	30,20	14	22,00	150	28	28,25	
455245G1	GAS1"	33,25	11	25,00	160	30	30,75	

44.0040

MACHINE TAP FOR ALUMINIUM HSS-E



-  Macho de máquina especial aluminio HSS-E
-  Taraud machine pour aluminium HSS-E
-  Maschio a macchina speciale per alluminio HSS-E
-  Машинные метчики для обработки алюминия HSS-E







				
				
				

M

Cod.	M	d1	P	d2	L1	L2	Prev. Hole Ø	Price €
440040M03	M3	3,00	0,50	3,50	56	10	2,50	
440040M04	M4	4,00	0,70	4,50	63	12	3,30	
440040M05	M5	5,00	0,80	6,00	70	14	4,20	
440040M06	M6	6,00	1,00	6,00	80	16	5,00	
440040M08	M8	8,00	1,25	8,00	90	17	6,80	
440040M10	M10	10,00	1,50	10,00	100	20	8,50	











MACHINE TAP FOR ALUMINIUM HSS-E

44.0046

-  Macho de máquina especial aluminio HSS-E
-  Taraud machine pour aluminium HSS-E
-  Maschio a macchina speciale per alluminio HSS-E
-  Машинные метчики для обработки алюминия HSS-E



THREAD LINE

				
				
				
	 p-192			





M

Cod.	M	d1	P	d2	L1	L2	Prev. Hole Ø	Price €
440046M12	M12	12,00	1,75	9,00	110	24	10,20	
440046M16	M16	16,00	2,00	12,00	110	26	14,00	
440046M20	M20	20,00	2,50	16,00	140	32	17,50	

43.2810

HIGH PERFORMANCE MACHINE TAP HSS-E-PM



-  Macho de máquina alto rendimiento HSS-E-PM
-  Taraud machine haute performance HSS-E-PM
-  Maschio a macchina ad alta prestazione HSS-E-PM
-  Машинные метчики высокопроизводительные HSS-E-PM







6HX tolerance	600 1400 N/mm ²	GG(G)	TiCN
		DIN 371A	HSS-E PM
		HPC	
		NEW	 p-192

M







Cod.	M	d1	P	d2	L1	L2	Prev. Hole Ø	Price €
432810M05	M5	5,00	0,80	6,00	70	14	4,20	
432810M06	M6	6,00	1,00	6,00	80	16	5,00	
432810M08	M8	8,00	1,25	8,00	90	17	6,80	
432810M10	M10	10,00	1,50	10,00	100	20	8,50	

HIGH PERFORMANCE MACHINE TAP HSS-E-PM

43.2816

-  Macho de máquina alto rendimiento HSS-E-PM
-  Taraud machine haute performance HSS-E-PM
-  Maschio a macchina ad alta prestazione HSS-E-PM
-  Машинные метчики высокопроизводительные HSS-E-PM



6HX tolerance	600 1400 N/mm ²	GG(G)	TiCN
		DIN 376A	HSS-E PM
		HPC	
		NEW	 p-192



THREAD LINE

M

Cod.	M	d1	P	d2	L1	L2	Prev. Hole Ø	Price €
432816M10	M10	10,00	1,50	7,00	100	20	8,50	
432816M12	M12	12,00	1,75	9,00	110	24	10,20	
432816M14	M14	14,00	2,00	11,00	110	26	12,00	







EVERYWHERE
YOU WORK



HIGH PERFORMANCE MACHINE TAP HSS-E-PM

43.2117

-  Macho de máquina alto rendimiento HSS-E-PM
-  Taraud machine haute performance HSS-E-PM
-  Maschio a macchina ad alta prestazione HSS-E-PM
-  Машинные метчики высокопроизводительные HSS-E-PM





6HX
tolerance

**600
1400**
N/mm²

GG(G)

TiCN







**DIN
376A**

**HSS-E
PM**





HPC





NEW

 p-192



THREAD LINE





MF

Cod.	M	d1	P	d2	L1	L2	Prev. Hole Ø	Price €
432117MF05050	MF5	5,00	0,50	3,50	70	10	4,50	
432117MF06050	MF6	6,00	0,50	4,50	80	13	5,50	
432117MF06075	MF6	6,00	0,75	4,50	80	13	5,20	
432117MF08075	MF8	8,00	0,75	6,00	80	14	7,20	
432117MF08100	MF8	8,00	1,00	6,00	90	16	7,00	
432117MF10100	MF10	10,00	1,00	7,00	90	16	9,00	
432117MF10125	MF10	10,00	1,25	7,00	100	20	9,30	
432117MF12100	MF12	12,00	1,00	9,00	100	20	11,00	
432117MF12125	MF12	12,00	1,25	9,00	100	20	10,80	
432117MF12150	MF12	12,00	1,50	9,00	100	20	10,50	
432117MF14150	MF14	14,00	1,50	11,00	100	20	12,50	
432117MF16150	MF16	16,00	1,50	12,00	100	22	14,50	





46.4040

HIGH PERFORMANCE MACHINE TAP HSS-E-PM



-  Macho de máquina alto rendimiento HSS-E-PM
-  Taraud machine haute performance HSS-E-PM
-  Maschio a macchina ad alta prestazione HSS-E-PM
-  Машинные метчики высокопроизводительные HSS-E-PM







6HX tolerance	NI ALLOYS	TITAN INCONEL	TiAlN
	DIN 371B	HSS-E PM	
	HA	HPC	
	NEW	 p-192	

M

Cod.	M	d1	P	d2	L1	L2	Prev. Hole Ø	Price €
464040M03	M3	3,00	0,50	3,50	56	10	2,50	
464040M04	M4	4,00	0,70	4,50	63	12	3,30	
464040M05	M5	5,00	0,80	6,00	70	14	4,20	
464040M06	M6	6,00	1,00	6,00	80	16	5,00	
464040M08	M8	8,00	1,25	8,00	90	17	6,80	
464040M10	M10	10,00	1,50	10,00	100	20	8,50	













HIGH PERFORMANCE MACHINE TAP HSS-E-PM

46.4046

-  Macho de máquina alto rendimiento HSS-E-PM
-  Taraud machine haute performance HSS-E-PM
-  Maschio a macchina ad alta prestazione HSS-E-PM
-  Машинные метчики высокопроизводительные HSS-E-PM



THREAD LINE

			
			
			
			p-192





M

Cod.	M	d1	P	d2	L1	L2	Prev. Hole Ø	Price €
464046M12	M12	12,00	1,75	9,00	110	24	10,20	
464046M16	M16	16,00	2,00	12,00	110	26	14,00	



43.2010

HIGH PERFORMANCE MACHINE TAP HARDENED STEELS



-  Macho de máquina alto rendimiento para aceros duros
-  Taraud machine haute performance pour aciers durs
-  Maschio a macchina ad alta prestazione per acciaio temprato HSS-E-PM
-  Машинные метчики высокопроизводительные по закаленной стали



6HX tolerance	42-54 HRC	TiCN
		HSS-E PM
	HA	HPC
OIL	NEW	HELION NORM





 p-192

M

Cod.	M	d1	P	d2	L1	L2	Prev. Hole Ø	Price €
432010M03	M3	3,00	0,50	3,50	56	10	2,60	
432010M04	M4	4,00	0,70	4,50	63	12	3,40	
432010M05	M5	5,00	0,80	6,00	70	14	4,30	
432010M06	M6	6,00	1,00	6,00	80	16	5,10	
432010M08	M8	8,00	1,25	8,00	90	17	6,90	
432010M10	M10	10,00	1,50	10,00	100	20	8,60	
432010M12	M12	12,00	1,75	12,00	110	24	10,40	
432010M14	M14	14,00	2,00	14,00	110	26	12,00	
432010M16	M16	16,00	2,00	16,00	110	26	14,10	



SOLID CARBIDE MACHINE TAP HARDENED STEELS

47.9010

-  Macho de máquina de metal duro para aceros duros
-  Taraud machine en carbure pour aciers durs
-  Maschio a macchina in metallo duro per acciaio temprato
-  Твердосплавные машинные метчики по закаленной стали



THREAD LINE

6H tolerance	48-63 HRC	TiCN
		HM
	HA	HPC
OIL	NEW	HELION NORM

 p-192

M





Cod.	M	d1	P	d2	L1	L2	Prev. Hole Ø	Price €
479010M03	M3	3,00	0,50	3,50	56	12	2,60	
479010M04	M4	4,00	0,70	4,50	63	14	3,40	
479010M05	M5	5,00	0,80	6,00	70	17	4,30	
479010M06	M6	6,00	1,00	6,00	80	20	5,10	
479010M08	M8	8,00	1,25	8,00	90	20	6,90	
479010M10	M10	10,00	1,50	10,00	100	24	8,60	
479010M12	M12	12,00	1,75	12,00	110	28	10,40	
479010M16	M16	16,00	2,00	16,00	110	40	14,10	

Usar la broca 62.6000 para los taladros previos al roscado, según los diámetros aconsejados para cada rosca
 Use drill bit 62.6000 for the holes prior to threading, according to the recommended diameters for each thread

40.1060

UNIVERSAL MACHINE TAP FIRST CHOICE HSS-E



-  Macho de máquina multiuso HSS-E
-  Taraud machine universel HSS-E
-  Maschio a macchina universale HSS-E
-  Машинные метчики общего применения HSS-E



6H
tolerance

Black
HVA

UNI

INOX



DIN
371C



HA



MQL





 p-192

M

Cod.	M	d1	P	d2	L1	L2	Prev. Hole Ø	Price €
401060M03	M3	3	0,50	3,50	56	6	2,50	
401060M04	M4	4	0,70	4,50	63	8	3,20	
401060M05	M5	5	0,80	6,00	70	9	4,20	
401060M06	M6	6	1,00	6,00	80	11	5,00	
401060M08	M8	8	1,25	8,00	90	14	6,80	
401060M10	M10	10	1,50	10,00	100	16	8,50	

UNIVERSAL MACHINE TAP FIRST CHOICE HSS-E

40.1066

-  Macho de máquina multiuso HSS-E
-  Taraud machine universel HSS-E
-  Maschio a macchina universale HSS-E
-  Машинные метчики общего применения HSS-E



THREAD LINE

6H
tolerance

Black
HVA

UNI

INOX

 DIN
376C

 HA

 MQL

 p-192





M

Cod.	M	d1	P	d2	L1	L2	Prev. Hole Ø	Price €
401066M12	M12	12,00	1,75	9,00	110	19	10,20	
401066M16	M16	16,00	2,00	12,00	110	20	14,00	
401066M20	M20	20,00	2,50	16,00	140	25	17,50	

40.1050

UNIVERSAL MACHINE TAP FIRST CHOICE HSS-E



-  Macho de máquina multiuso HSS-E
-  Taraud machine universel HSS-E
-  Maschio a macchina universale HSS-E
-  Машинные метчики общего применения HSS-E



6H
tolerance

Black
HVA

UNI

INOX



DIN
371E



HA



MQL

 p-192

FORM E

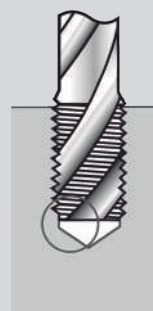





M

Cod.	M	d1	P	d2	L1	L2	Prev. Hole Ø	Price €
401050M03	M3	3,00	0,50	3,50	56	6	2,50	
401050M04	M4	4,00	0,70	4,50	63	8	3,20	
401050M05	M5	5,00	0,80	6,00	70	9	4,20	
401050M06	M6	6,00	1,00	6,00	80	11	5,00	
401050M08	M8	8,00	1,25	8,00	90	14	6,80	
401050M10	M10	10,00	1,50	10,00	100	16	8,50	

UNIVERSAL MACHINE TAP 6G TOLERANCE HSS-E

40.1660

-  Macho de máquina multiuso Tol. 6G HSS-E
-  Taraud machine universel Tol. 6G HSS-E
-  Maschio a macchina universale tolleranza 6G HSS-E
-  Машинные метчики общего применения "6G" HSS-E



THREAD LINE

6G
tolerance

Black
HVA

UNI

INOX

 DIN
371C

 HA

 MQL

 p-192





M

Cod.	M	d1	P	d2	L1	L2	Prev. Hole Ø	Price €
401660M03	M3	3,00	0,50	3,50	56	6	2,50	
401660M04	M4	4,00	0,70	4,50	63	8	3,20	
401660M05	M5	5,00	0,80	6,00	70	9	4,20	
401660M06	M6	6,00	1,00	6,00	80	11	5,00	
401660M08	M8	8,00	1,25	8,00	90	14	6,80	
401660M10	M10	10,00	1,50	10,00	100	16	8,50	

40.1160

UNIVERSAL MACHINE TAP FIRST CHOICE HSS-E



-  Macho de máquina multiuso HSS-E
-  Taraud machine universel HSS-E
-  Maschio a macchina universale prima scelta HSS-E
-  Машинные метчики общего применения HSS-E





6H
tolerance

Black
HVA

UNI

INOX

DIN
376C

HA

MQL





 p-192

MF

Cod.	M	d1	P	d2	L1	L2	Prev. Hole Ø	Price €
401160MF405	MF4	4,00	0,50	2,80	63	5	3,50	
401160MF505	MF5	5,00	0,50	3,50	70	5	4,50	
401160MF6075	MF6	6,00	0,75	4,50	80	8	5,25	
401160MF81	MF8	8,00	1,00	6,00	90	11	7,00	
401160MF101	MF10	10,00	1,00	7,00	90	11	9,00	
401160MF10125	MF10	10,00	1,25	7,00	100	14	8,80	
401160MF121	MF12	12,00	1,00	9,00	100	11	11,00	
401160MF12125	MF12	12,00	1,25	9,00	100	16	10,80	
401160MF1215	MF12	12,00	1,50	9,00	100	16	10,50	
401160MF141	MF14	14,00	1,00	11,00	100	11	13,00	
401160MF1415	MF14	14,00	1,50	11,00	100	15	12,50	
401160MF161	MF16	16,00	1,00	12,00	100	11	15,00	
401160MF1615	MF16	16,00	1,50	12,00	100	15	14,50	
401160MF2015	MF20	20,00	1,50	16,00	125	16	18,50	

UNIVERSAL MACHINE TAP FIRST CHOICE HSS-E

40.1260

-  Macho de máquina multiuso HSS-E
-  Taraud machine universel HSS-E
-  Maschio a macchina universale prima scelta HSS-E
-  Машинные метчики общего применения HSS-E



THREAD LINE

Black
HVA

UNI

INOX



DIN
5156





MQL



p-192





**GAS
BSP**

Cod.	Size	d1	P	d2	L1	L2	Prev. Hole Ø	Price €
401260G18	GAS1/8	9,73	28	7,00	90	11	8,80	
401260G14	GAS1/4	13,16	19	11,00	100	14	11,80	
401260G38	GAS3/8	16,66	19	12,00	100	14	15,25	
401260G12	GAS1/2	20,96	14	16,00	125	18	19,00	
401260G34	GAS3/4	26,44	14	20,00	140	20	24,50	
401260G1	GAS1"	33,25	11	25,00	160	24	30,75	

40.1360

UNIVERSAL MACHINE TAP FIRST CHOICE HSS-E



-  Macho de máquina multiuso HSS-E
-  Taraud machine universel HSS-E
-  Maschio a macchina universale prima scelta HSS-E
-  Машинные метчики общего применения HSS-E





2B
tolerance

Black
HVA



UNI

INOX

 DIN
374C

 HA

HPC

  MQL





 p-192

**UNF
SAE**

Cod.	Size	d1	P	d2	L1	L2	Prev. Hole Ø	Price €
401360NF448	UNF4	2,85	48	2,20	56	6	2,40	
401360NF640	UNF6	3,51	40	2,50	56	7	2,95	
401360NF1032	UNF10	4,83	32	3,50	70	9	4,10	
401360NF1428	UNF1/4	6,35	28	4,50	80	9	5,50	
401360NF3824	UNF3/8	9,53	24	7,00	90	11	8,50	
401360NF5818	UNF5/8	15,88	18	12,00	100	15	14,50	

UNIVERSAL MACHINE TAP FIRST CHOICE HSS-E

40.1460
40.1466

-  Macho de máquina multiuso HSS-E
-  Taraud machine universel HSS-E
-  Maschio a macchina universale prima scelta HSS-E
-  Машинные метчики общего применения HSS-E





2B
tolerance

Black
HVA

UNI

INOX

DIN
374C

HA

MQL

p-192





UNC

Cod.	Size	d1	P	d2	L1	L2	Prev. Hole Ø	Price €
4014600NC440	UNC4	2,85	40	3,50	56	7	2,35	
4014600NC632	UNC6	3,51	32	4,00	56	8	2,85	
4014600NC832	UNC8	4,17	32	4,50	63	8	3,50	
401460NC1024	UNC10	4,83	24	6,00	70	11	3,90	
401460NC1420	UNC1/4	6,35	20	7,00	80	13	5,10	
401460NC51618	UNC5/16	7,94	18	8,00	90	14	6,60	
401460NC3816	UNC3/8	9,53	16	10,00	100	16	8,00	
401466NC71614	UNC7/16	11,11	14	8,00	100	18	9,40	
401466NC1213	UNC1/2	12,7	13	9,00	110	20	10,80	
401466NC5811	UNC5/8	15,88	11	12,00	110	24	13,50	
401466NC3410	UNC3/4	19,05	10	14,00	125	25	16,50	

40.7068

UNIVERSAL MACHINE TAP LONG HSS-E



-  Macho de máquina multiuso largo HSS-E
-  Taraud machine universel long HSS-E
-  Maschio a macchina universale lungo HSS-E
-  Машинные метчики общего применения, длинная серия HSS-E

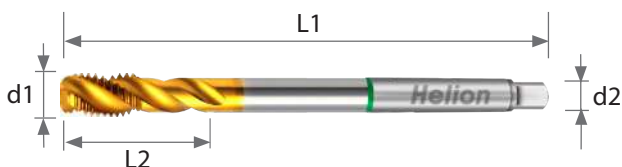

6HX
tolerance

TiN
Up

UNI

INOX



HA

HPC



MQL

HELION
NORM

 p-192

M

Cod.	M	d1	P	d2	L1	L2	Prev. Hole Ø	Price €
407068M03	M3	3,00	0,50	3,50	112	6	2,50	
407068M04	M4	4,00	0,70	2,80	112	8	3,20	
407068M05	M5	5,00	0,80	3,50	125	9	4,20	
407068M06	M6	6,00	1,00	4,50	125	11	5,00	
407068M08	M8	8,00	1,25	6,00	140	14	6,80	
407068M10	M10	10,00	1,50	7,00	160	16	8,50	
407068M12	M12	12,00	1,75	9,00	180	19	10,20	
407068M16	M16	16,00	2,00	12,00	220	20	14,00	
407068M20	M20	20,00	2,50	16,00	280	25	17,50	



MILL  **LINE**

DRILL  **LINE**

THREAD  **LINE**

REAM  **LINE**

Our speciality is the design and manufacturing of all kinds of solid carbide cutting tools: End mills, drills, reamers, taps and special tools.

Our business philosophy is to provide our customers with comprehensive **solutions that improve machining operations, increase productivity, and reduce costs.** Service + Quality + Performance.

More information + 34 93 877 08 69
Barcelona - Spain

Somos especialistas en el **diseño y la fabricación de todo tipo de herramientas de metal duro: fresas, brocas, escariadores, machos y herramientas especiales.**

Nuestra filosofía de negocio ofrece a nuestros clientes **soluciones integrales que permiten mejorar las operaciones de mecanizado, aumentar la productividad y reducir los costes.** Servicio, Calidad y Funcionamiento.





Más información + 34 93 877 08 69
Barcelona - España

www.helion-tools.com

WORKING FOR YOUR SUCCESS Since 1952

40.7060

UNIVERSAL MACHINE TAP FIRST CHOICE HSS-E

-  Macho de máquina multiuso HSS-E
-  Taraud machine universel HSS-E
-  Maschio a macchina universale HSS-E
-  Машинные метчики общего применения HSS-E

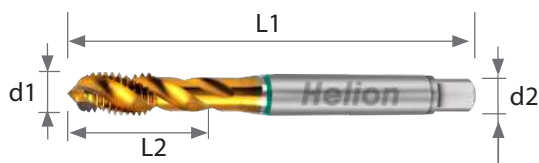



6H
tolerance

TiN
Up

UNI

INOX

 **DIN**
371C

 **HA**

HPC

 **MQL**





 **p-192**

M

Cod.	M	d1	P	d2	L1	L2	Prev. Hole Ø	Price €
407060M02	M2	2,00	0,40	2,80	45	5	1,60	
407060M03	M3	3,00	0,50	3,50	56	6	2,50	
407060M04	M4	4,00	0,70	4,50	63	8	3,20	
407060M05	M5	5,00	0,80	6,00	70	9	4,20	
407060M06	M6	6,00	1,00	6,00	80	11	5,00	
407060M08	M8	8,00	1,25	8,00	90	14	6,80	
407060M10	M10	10,00	1,50	10,00	100	16	8,50	

UNIVERSAL MACHINE TAP FIRST CHOICE HSS-E

40.7066

-  Macho de máquina multiuso HSS-E
-  Taraud machine universel HSS-E
-  Maschio a macchina universale HSS-E
-  Машинные метчики общего применения HSS-E



THREAD LINE

6HX
tolerance

TiN
Up

UNI

INOX

DIN
376C

HA
HPC

MQL

p-192





M

Cod.	M	d1	P	d2	L1	L2	Prev. Hole Ø	Price €
407066M12	M12	12,00	1,75	9,00	110	19	10,20	
407066M14	M14	14,00	2,00	11,00	110	20	12,00	
407066M16	M16	16,00	2,00	12,00	110	20	14,00	
407066M20	M20	20,00	2,50	16,00	140	25	17,50	
407066M24	M24	24,00	3,00	18,00	160	30	21,00	

41.6050

UNIVERSAL MACHINE TAP PERFORMANCE HSS-E-PM



-  Macho de máquina multiuso producción HSS-E-PM
-  Taraud machine universel performance HSS-E-PM
-  Maschio a macchina universale prestazione HSS-E-PM
-  Машинные метчики общего применения HSS-E-PM







6H tolerance	600 1400 N/mm ²	TiN Up	UNI
	DIN 371C	HSS-E PM	
	HA	HPC	HSC
	MQL	NEW	 p-192

M

Cod.	M	d1	P	d2	L1	L2	Prev. Hole Ø	Price €
416050M03	M3	3,00	0,50	3,50	56	6	2,50	
416050M04	M4	4,00	0,70	4,50	63	8	3,20	
416050M05	M5	5,00	0,80	6,00	70	9	4,20	
416050M06	M6	6,00	1,00	6,00	80	11	5,00	
416050M08	M8	8,00	1,25	8,00	90	14	6,80	
416050M10	M10	10,00	1,50	10,00	100	16	8,50	







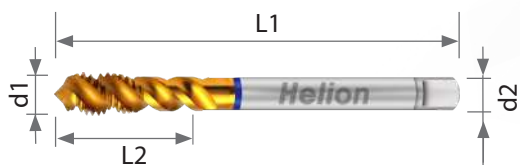



UNIVERSAL MACHINE TAP PERFORMANCE HSS-E-PM

41.6056

-  Macho de máquina multiuso producción HSS-E-PM
-  Taraud machine universel performance HSS-E-PM
-  Maschio a macchina universale prestazione HSS-E-PM
-  Машинные метчики общего применения HSS-E-PM



THREAD LINE

			
			
			 p-192





M

Cod.	M	d1	P	d2	L1	L2	Prev. Hole Ø	Price €
416056M12	M12	12,00	1,75	9,00	110	19	10,20	
416056M14	M14	14,00	2,00	11,00	110	20	12,00	
416056M16	M16	16,00	2,00	12,00	110	20	14,00	
416056M20	M20	20,00	2,50	16,00	140	25	17,50	

45.4060

HIGH PERFORMANCE MACHINE TAP HSS-E



-  Macho de máquina alto rendimiento HSS-E
-  Taraud machine haute performance HSS-E
-  Maschio a macchina ad alta prestazione HSS-E
-  Машинные метчики высокопроизводительные HSS-E







			
			
			

M











Cod.	M	d1	P	d2	L1	L2	Prev. Hole Ø	Price €
454060M02	M2	2,00	0,40	2,80	45	5	1,60	
454060M03	M3	3,00	0,50	3,50	56	6	2,50	
454060M04	M4	4,00	0,70	4,50	63	8	3,30	
454060M05	M5	5,00	0,80	6,00	70	9	4,20	
454060M06	M6	6,00	1,00	6,00	80	11	5,00	
454060M08	M8	8,00	1,25	8,00	90	14	6,80	
454060M10	M10	10,00	1,50	10,00	100	16	8,50	

HIGH PERFORMANCE MACHINE TAP HSS-E

45.4066

-  Macho de máquina alto rendimiento HSS-E
-  Taraud machine haute performance HSS-E
-  Maschio a macchina ad alta prestazione HSS-E
-  Машинные метчики высокопроизводительные HSS-E







M

Cod.	M	d1	P	d2	L1	L2	Prev. Hole Ø	Price €
454066M12	M12	12,00	1,75	9,00	110	19	10,20	
454066M14	M14	14,00	2,00	11,00	110	20	12,00	
454066M16	M16	16,00	2,00	12,00	110	20	14,00	
454066M18	M18	18,00	2,50	14,00	125	25	15,50	
454066M20	M20	20,00	2,50	16,00	140	25	17,50	
454066M24	M24	24,00	3,00	18,00	160	30	21,00	
454066M30	M30	30,00	3,50	22,00	180	35	26,50	











45.4164

HIGH PERFORMANCE MACHINE TAP HSS-E



-  Macho de máquina alto rendimiento HSS-E
-  Taraud machine haute performance HSS-E
-  Maschio a macchina ad alta prestazione HSS-E
-  Машинные метчики высокопроизводительные HSS-E







			
			
			

MF

Cod.	M	d1	P	d2	L1	L2	Prev. Hole Ø	Price €
454164MF6075	MF6	6,00	0,75	4,50	80	8	5,20	
454164MF8075	MF8	8,00	0,75	6,00	80	8	7,20	
454164MF81	MF8	8,00	1,00	6,00	90	11	7,00	
454164MF101	MF10	10,00	1,00	7,00	90	11	9,00	
454164MF10125	MF10	10,00	1,25	7,00	100	14	8,80	
454164MF121	MF12	12,00	1,00	9,00	100	11	11,00	
454164MF12125	MF12	12,00	1,25	9,00	100	16	10,80	
454164MF1215	MF12	12,00	1,50	9,00	100	16	10,50	
454164MF1415	MF14	14,00	1,50	11,00	100	15	12,50	
454164MF1615	MF16	16,00	1,50	12,00	100	15	14,50	
454164MF1815	MF18	18,00	1,50	14,00	110	16	16,50	
454164MF2015	MF20	20,00	1,50	16,00	125	16	18,50	
454164MF2415	MF24	24,00	1,50	18,00	140	16	22,50	











HIGH PERFORMANCE MACHINE TAP HSS-E

45.3265

-  Macho de máquina alto rendimiento HSS-E
-  Taraud machine haute performance HSS-E
-  Maschio a macchina ad alta prestazione HSS-E
-  Машинные метчики высокопроизводительные HSS-E



THREAD LINE





		
		
		
		

**GAS
BSP**

Cod.	Size	d1	P	d2	L1	L2	Prev. Hole Ø	Price €
453265G116	GAS1/16	7,72	28	6,00	90	11	6,80	
453265G18	GAS1/8	9,73	28	7,00	90	11	8,80	
453265G14	GAS1/4	13,16	19	11,00	100	14	11,80	
453265G38	GAS3/8	16,66	19	12,00	100	14	15,25	
453265G12	GAS1/2	20,96	14	16,00	125	18	19,00	
453265G58	GAS5/8	22,91	14	18,00	125	18	21,00	
453265G34	GAS3/4	26,44	14	20,00	140	20	24,50	
453265G78	GAS7/8	30,20	14	22,00	150	22	28,25	
453265G1	GAS1"	33,25	11	25,00	160	24	30,75	

44.0060

MACHINE TAP FOR ALUMINIUM HSS-E

-  Macho de máquina especial aluminio HSS-E
-  Taraud machine pour aluminium HSS-E
-  Maschio a macchina ad alta prestazione HSS-E
-  Машинные метчики для обработки алюминия HSS-E

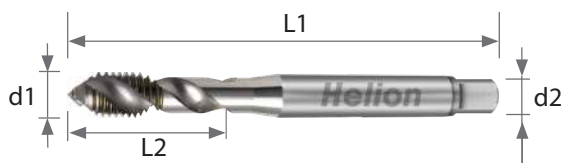

6H
tolerance

ALU
NE

PLASTIC

GFK
CFK

BRIGHT

 **DIN**
371C

 **HA**

HPC

 **NEW**





 **p-192**

M

Cod.	M	d1	P	d2	L1	L2	Prev. Hole Ø	Price €
440060M03	M3	3,00	0,50	3,50	56	6	2,50	
440060M04	M4	4,00	0,70	4,50	63	8	3,30	
440060M05	M5	5,00	0,80	6,00	70	9	4,20	
440060M06	M6	6,00	1,00	6,00	80	11	5,00	
440060M08	M8	8,00	1,25	8,00	90	14	6,80	
440060M10	M10	10,00	1,50	10,00	100	16	8,50	

MACHINE TAP FOR ALUMINIUM HSS-E

44.0066

-  Macho de máquina especial aluminio HSS-E
-  Taraud machine pour aluminium HSS-E
-  Maschio a macchina ad alta prestazione HSS-E
-  Машинные метчики для обработки алюминия HSS-E



6H
tolerance

PLASTIC

GFK
CFK

ALU
NE

BRIGHT

 DIN
376C

 HA

HPC

 NEW





 p-192

M













Cod.	M	d1	P	d2	L1	L2	Prev. Hole Ø	Price €
440066M12	M12	12,00	1,75	9,00	110	19	10,20	
440066M16	M16	16,00	2,00	12,00	110	20	14,00	
440066M20	M20	20,00	2,50	16,00	140	25	17,50	

46.4070

HIGH PERFORMANCE MACHINE TAP HSS-E-PM

-  Macho de máquina alto rendimiento HSS-E-PM
-  Taraud machine haute performance HSS-E-PM
-  Maschio a macchina ad alta prestazione HSS-E-PM
-  Машинные метчики высокопроизводительные HSS-E-PM







			
			
			
			p-192

M

Cod.	M	d1	P	d2	L1	L2	Prev. Hole Ø	Price €
464070M03	M3	3,00	0,50	3,50	56	10	2,50	
464070M04	M4	4,00	0,70	4,50	63	12	3,30	
464070M05	M5	5,00	0,80	6,00	70	14	4,20	
464070M06	M6	6,00	1,00	6,00	80	16	5,00	
464070M08	M8	8,00	1,25	8,00	90	17	6,80	
464070M10	M10	10,00	1,50	10,00	100	20	8,50	





HIGH PERFORMANCE MACHINE TAP HSS-E-PM

46.4076

-  Macho de máquina alto rendimiento HSS-E-PM
-  Taraud machine haute performance HSS-E-PM
-  Maschio a macchina ad alta prestazione HSS-E-PM
-  Машинные метчики высокопроизводительные HSS-E-PM



THREAD LINE

6HX tolerance	NI ALLOYS	TITAN INCONELL	TiAlN
	DIN 376C	HSS-E PM	
	HA	HPC	
	MQL	NEW	 p-192

M

Cod.	M	d1	P	d2	L1	L2	Prev. Hole Ø	Price €
464076M12	M12	12,00	1,75	9,00	110	24	10,20	
464076M16	M16	16,00	2,00	12,00	110	26	14,00	

CUTTING CONDITIONS SOLID CARBIDE THREAD MILL 2XD



CODE 4990		Ø1	Ø1,5	Ø2	Ø3	Ø4	Ø5	Ø6	Ø7	Ø8	Ø9	Ø10	Ø12	Ø14	Ø15	
		Vc	fz mm	fz mm	fz mm	fz mm	fz mm	fz mm	fz mm	fz mm	fz mm	fz mm	fz mm	fz mm	fz mm	fz mm
Steel	Low carbon content steels	60-120	0,04	0,05	0,05	0,07	0,09	0,11	0,13	0,14	0,15	0,16	0,16	0,17	0,18	0,18
	Highly bound steels	60-90	0,03	0,04	0,05	0,06	0,08	0,09	0,1	0,12	0,13	0,14	0,14	0,16	0,17	0,18
	Bound steels - Steels capable of being hardened and tempered	50-80	0,03	0,04	0,04	0,05	0,05	0,06	0,07	0,07	0,08	0,09	0,10	0,12	0,13	0,14
Inox	Stainless steels	60-90	0,02	0,03	0,03	0,04	0,05	0,06	0,06	0,07	0,08	0,09	0,10	0,11	0,12	0,13
	Casting steels	70-90	0,03	0,04	0,04	0,05	0,05	0,06	0,07	0,07	0,08	0,09	0,10	0,12	0,13	0,14
Cast Iron	Cast iron	40-80	0,04	0,05	0,05	0,07	0,09	0,11	0,13	0,14	0,15	0,16	0,16	0,17	0,18	0,18
Non ferrous	Aluminium	80-150	0,04	0,05	0,05	0,07	0,09	0,11	0,13	0,14	0,15	0,16	0,16	0,17	0,18	0,18
	Thermosetting plastic materials	50-200	0,09	0,10	0,11	0,12	0,14	0,16	0,18	0,19	0,19	0,19	0,19	0,19	0,2	0,2
	Thermoplastics	50-200	0,09	0,10	0,11	0,12	0,14	0,16	0,18	0,19	0,19	0,19	0,19	0,19	0,2	0,2
Special materials	Nickel and titanium alloys	20-40	0,03	0,03	0,03	0,04	0,04	0,05	0,06	0,06	0,06	0,07	0,07	0,07	0,08	0,08

CUTTING CONDITIONS SOLID CARBIDE THREAD MILL 2XD



CODE 4991			fz			
			Vc	Ø d1 ≤ 4 mm	Ø d1 ≤ 8 mm	Ø d1 > 8 mm
Steel	Cold-struded steels / Structural steels / Hig speed steels, etc...	≤ 600 N/mm ²	80-250	0,005 - 0,04	0,04 - 0,07	0,05 - 0,15
	Structural steels / Casehardened steels / Steel casting etc..	≤ 800 N/mm ²	60-150	0,005 - 0,04	0,04 - 0,07	0,05 - 0,15
	Casehardened steels / Steels capable of being hardened and tempered / Cold-working steels etc...	≤ 1000 N/mm ²	40-120	0,005 - 0,03	0,03 - 0,05	0,04 - 0,12
	Steels capable of being hardened and tempered / Cold-working steels etc... / Nitrided steels, etc...	≤ 1200 N/mm ²	40-120	0,003 - 0,02	0,02 - 0,05	0,04 - 0,12
	Highly bound steels / Cold-working steels etc... / Hot-working steels, etc..	≤ 1400 N/mm ²	40-120	0,003 - 0,02	0,02 - 0,05	0,04 - 0,12
Inox	Ferritic, martensitic	≤ 600 N/mm ²	40-120	0,003 - 0,03	0,03 - 0,05	0,04 - 0,12
	Austenitic	≤ 800 N/mm ²	40-120	0,003 - 0,03	0,03 - 0,05	0,04 - 0,12
	Austenitic - Ferritic	≤ 1000 N/mm ²	30-80	0,003 - 0,02	0,02 - 0,05	0,04 - 0,10
Cast Iron	Cast irons with laminar graphite	≤ 100-250 N/mm ²	100-200		0,04 - 0,07	0,05 - 0,15
		≤ 250-450 N/mm ²	100-200		0,04 - 0,07	0,05 - 0,15
	Cast irons with nodular graphite	≤ 350-500 N/mm ²	80-200		0,04 - 0,07	0,05 - 0,15
		≤ 500-900 N/mm ²	80-200		0,04 - 0,07	0,05 - 0,15
	Cast irons with vermicular graphite	≤ 300-400 N/mm ²	80-200		0,04 - 0,07	0,05 - 0,15
	≤ 400-500 N/mm ²	80-200		0,04 - 0,07	0,05 - 0,15	
	Malleable cast irons	≤ 250-500 N/mm ²	80-200		0,04 - 0,07	0,05 - 0,15
		≤ 500-800 N/mm ²	80-200		0,04 - 0,07	0,05 - 0,15
Non ferrous		≤ 200 N/mm ²	150-400	0,01 - 0,05	0,05 - 0,08	0,07 - 0,20
	Malleable aluminum alloys	≤ 350 N/mm ²	150-400	0,01 - 0,05	0,05 - 0,08	0,07 - 0,20
		≤ 550 N/mm ²	150-400	0,01 - 0,05	0,05 - 0,08	0,07 - 0,20
		Si ≤ 7%	150-400	0,01 - 0,05	0,05 - 0,08	0,07 - 0,20
	Cast irons with nodular graphite	7% < Si ≤ 12%	150-400	0,01 - 0,05	0,05 - 0,08	0,07 - 0,20
		12% < Si ≤ 17%	100-200	0,01 - 0,05	0,05 - 0,08	0,07 - 0,20
	Pure copper, slightly bound copper	≤ 400 N/mm ²	150-400	0,008 - 0,05	0,05 - 0,08	0,07 - 0,20
	Copper alloys - Zinc (Brass, long chip)	≤ 550 N/mm ²	150-400	0,008 - 0,05	0,05 - 0,08	0,07 - 0,20
	Copper alloys - Zinc (Brass,short chip)	≤ 550 N/mm ²	150-400	0,008 - 0,05	0,05 - 0,08	0,07 - 0,20
	Copper alloys - Aluminium (Alubronze, long chip)	≤ 800 N/mm ²	100-250	0,008 - 0,04	0,04 - 0,07	0,05 - 0,15
	Copper alloys - TiN (Bronze, long chip)	≤ 700 N/mm ²	100-250	0,008 - 0,04	0,04 - 0,07	0,05 - 0,15
	Copper alloys - TiN (Bronze, short chip)	≤ 400 N/mm ²	100-250	0,008 - 0,04	0,04 - 0,07	0,05 - 0,15
	Special copper alloys	≤ 600 N/mm ²	40-80	0,003 - 0,02	0,02 - 0,05	0,04 - 0,15
		≤ 1400 N/mm ²	30-60	0,003 - 0,02	0,02 - 0,05	0,04 - 0,15
	Malleable magnesium alloys	≤ 500 N/mm ²	150-400	0,01 - 0,05	0,05 - 0,08	0,07 - 0,20
	Magnesium casting alloys	≤ 500 N/mm ²	150-400	0,01 - 0,05	0,05 - 0,08	0,07 - 0,20
	Thermosetting plastic materials (short chip)		100-400	0,01 - 0,05	0,05 - 0,10	0,08 - 0,25
	Thermoplastic resins (long chip)		100-400	0,01 - 0,05	0,05 - 0,10	0,08 - 0,25
	Epossidic resins (fibre porcentaje ≤ 30%)		80-120	0,01 - 0,05	0,05 - 0,10	0,08 - 0,25
	Epossidic resins (fibre porcentaje > 30%)		80-120	0,01 - 0,05	0,05 - 0,10	0,08 - 0,25
Graphite		100-200		0,04 - 0,07	0,08 - 0,25	
Tungsten alloys - copper		30-60		0,02 - 0,04	0,08 - 0,25	
Composites					0,08 - 0,25	
Special materials	Pure titanium	≤ 450 N/mm ²	30-80	0,003 - 0,03	0,03 - 0,05	0,04 - 0,10
	Titanium alloys	≤ 900 N/mm ²	30-80	0,003 - 0,03	0,03 - 0,05	0,04 - 0,10
		≤ 1250 N/mm ²	30-60	0,003 - 0,02	0,02 - 0,04	0,03 - 0,08
	Pure nickel	≤ 600 N/mm ²	30-60	0,003 - 0,02	0,02 - 0,04	0,03 - 0,08
	Nickel base alloys	≤ 1000 N/mm ²	30-60	0,003 - 0,02	0,02 - 0,04	0,03 - 0,08
		≤ 1600 N/mm ²	30-40	0,003 - 0,02	0,02 - 0,04	0,03 - 0,08
	Cobalt base alloys	≤ 1000 N/mm ²	30-60	0,003 - 0,02	0,02 - 0,04	0,03 - 0,08
	≤ 1600 N/mm ²	30-40	0,003 - 0,02	0,02 - 0,04	0,03 - 0,08	
Hard materials		40-50 HRC	30-60		0,015 - 0,04	0,03 - 0,08
		50-55 HRC	30-60		0,015 - 0,04	0,03 - 0,08
	High resistance steels, tempered steels	Cast iron mold	55-60 HRC			
			60-63 HRC			
			63-66 HRC			

CUTTING CONDITIONS



Reference Group / Family color		Reference group / Family color							
		40	41	43	44	45	46	47	48
Tap material		HSS-E	HSS-E PM	HSS-E	HSS-E	HSS-E	HSS-E	HM	HSS-E
Coating		Black HVA	TiN Up	TiAlN	Brigh	TiAlN	TiAlN/TiCN	TiAlN	TiN Up
		Vc m/min.							
Steel	Unalloyed steel / Acero no aleado ≤ 800 N/mm ²	10-20	15-22			18-20			15-20
	Alloyed steel / Aceros aleados > 800 N/mm ² ≤ 1000 N/mm ²	10-15	15-20	15-20		18-20			12-15
	Alloyed steel / Aceros aleados ≤ 1200 N/mm ²	8-12	10-18	12-15		12-15			10-12
	Alloyed steel / Aceros aleados ≤ 1300 N/mm ²	6-10	8-12						8-10
Hard Steels	Hard Steels 42-52 HRC Only with Tap ref. 43.2010 HSS PM			3-5					
	Hard Steels 48-63 HRC Tap ref. 47.9010 Solid Carbide							2-3	
Inox	Stainless steel / Inoxidables	6-12	8-12			8-15			5-8
Cast Iron	Grey cast iron / Fundición gris $\leq 350-500$ N/mm ²	15-20	20-25	20-35		18-25			
	Nodular cast iron / Fundición nodular $\leq 300-400$ N/mm ²	15-20	20-25	20-30		20-25			
Non ferrous	Unalloyed copper / Cobre no aleado				12-20				
	Brass, Bronze / Laton, Bronce <200HB-	10-20	15-25			25-30			20
	Brass, Bronze / Laton, Bronce 200HB - 300HB	10-20	15-22	15-22					20
	Brass, Bronze / Laton, Bronce > 300HB	10-15	15-20	15-20					20
	Unalloyed Aluminium / Aluminio no aleado	15-25	10-18		15-25	15-25			20
	Alloyed Aluminium / Aluminio aleado 2% - 10% Si	15-20	20-25	12-20	15-25	15-25			20
	Alloyed Aluminium / Aluminio aleado 10% - 15% Si	10-18	20-25	10-15					
Special materials	Pure Titanium / Titanio puro					2-3	3-5		
	Alloyed Titanium / Aleaciones de Titanio <900N/mm ²					2-3	2-4		
	Alloyed Titanium / Aleaciones de Titanio <900 N/mm ² - 1500 N/mm ²						3		
	Pure nickel / Niquel puro					2-3	4		
	Alloyed Nickel / Aleaciones de Niquel <900 N/mm ²					2-3	4		
	Alloyed Nickel / Aleaciones de Niquel <900 N/mm ² - 1500 N/mm ²						3		